

Current part is item (10) on diagram. Available at www.oshkoshequipment.com

(1) SMR Code	(2) Federal Stock Number	DESCRIPTION	UNIT of meas	Qty inc. in Unit	30-day DS maint allowance			30-day GS maint allowance			1-yr aw per 100 equip cnt- gcy	Depot maint aw per 100 equip	Illustration		
					(a) 1-20	(b) 21-50	(c) 51-100	(a) 1-20	(b) 21-50	(c) 51-100			(a) Figure No.	(b) Item No.	
		Reference Number & Mfr. Code													
		Usable On Code													
PAOZZ	4730-542-5599	ELBOW, PIPE: CRANKCASE DRAIN COCK 44405 (24617)	EA	1	*	*	*	*	*	*	*	*		1	2
PAFZZ	5310-732-0558	NUT, PLAIN, HEXAGON: PUMP ADAPTER AND FRONT PLATE MTG MS51967-8 (96906)	EA	4	*	*	*	*	*	*	*	*		1	3
PAFZZ	5310-959-4675	WASHER, LOCK: PUMP ADAPTER AND FRONT PLATE MTG MS35340-46 (96906)	EA	10	*	*	*	*	*	*	*	*		1	4
PAFZZ	2815-477-6245	ADAPTER, INJECTION PUMP 10889793 (19207)	EA	1	*	*	*	*	*	*	*	*		1	5
PAFZZ	2815-420-9062	ADAPTER, FUEL INJECTION: 10889776 (19207)	EA	1	*	*	*	*	*	*	*	*		1	6
PAFZZ	5307-443-9865	STUD, PLAIN: ADAPTER MTG 10898712 (19207)	EA	2	*	*	*	*	*	*	*	*		1	7
PAFZZ	2910-862-9064	GASKET: PUMP ADAPTER MTG 10889723 (19207)	EA	1	*	*	*	*	*	*	*	*		1	8
PAFZZ	5307-903-7674	STUD, PLAIN: FRONT PLATE MTG 7375681-1 (19207)	EA	1	*	*	*	*	*	*	*	*		1	9
KFFZZ		GASKET: FRONT PLATE MTG 10889737 (19207)	EA	1	SEE SET	2815-864-0299								1	10
PAFZZ	2815-136-1200	PLATE ASSEMBLY, ENGINE: FRONT 10889744-1 (19207)	EA	1	*	*	*	*	*	*	*	*		1	11
PAFZZ	5307-904-9601	STUD, PLAIN: FRONT PLATE AND PUMP ADAPTER MTG 10899081 (19207)	EA	2	*	*	*	*	*	*	*	*		1	12
PAFZZ	2815-136-1199	COVER, TIMING GEAR, INSPECTION: 10889739 (19207)	EA	1	*	*	*	*	*	*	*	*		1	13
PAFZZ	5305-269-3223	SCREW, CAP, HEXAGON HEAD: ENGINE FRONT PLATE TO GEAR COVER AND HYDRAULIC PUMP MTG MS90725-73 (96906)	EA	2	*	*	*	*	*	*	*	*		1	14
PAFZZ	5305-269-3211	SCREW, CAP, HEXAGON HEAD: FRONT PLATE TO CRANKCASE MS90725-60 (96906)	EA	6	*	*	*	*	*	*	*	*		1	15
PAFZZ	4730-044-4655	PLUG, PIPE: CRANKCASE 444655 (19207)	EA	1	*	*	*	*	*	*	*	*		1	16
PAFZZ	4730-221-2141	PLUG, PIPE: TURBOCHARGER DRAIN HOLE MS20913-8S (96906)	EA	1	*	*	*	*	*	*	*	*		1	17
PAFZZ	4730-221-2138	PLUG, PIPE: TURBOCHARGER OIL SUPPLY HOLE MS20913-3S (96906)	EA	1	*	*	*	*	*	*	*	*		1	18
XAHZZ		CYLINDER BLOCK AND CRANKCASE ASSEMBLY: MULTIFUEL 10889802 (19207)		1										1	19
PAFZZ	5315-498-7029	PIN, STRAIGHT, HEADLESS: CRANKCASE 10898728 (19207)	EA	2	*	*	*	*	*	*	*	*		1	20
PAFZZ	5307-477-3735	STUD, PLAIN: FUEL FILTER TO CRANKCASE AND TAPPET COVER 8758517 (19207)	EA	3	*	*	*	*	*	*	*	*		1	21
PAFZZ	5307-903-7675	STUD, PLAIN: CRANKCASE TO FLYWHEEL HOUSING 8758528 (19207)	EA	6	*	*	*	*	*	*	*	*		1	22
PAHZZ	5307-057-4507	STUD, PLAIN: CRANKCASE TO FLYWHEEL HOUSING 8758520 (19207)	EA	2	*	*	*	*	*	*	*	*		1	23
PAHZZ	5315-412-2002	PIN, HOLLOW: CRANKCASE TO FLYWHEEL HOUSING 7748968 (19207)	EA	2	*	*	*	*	*	*	*	*		1	24
XAHZZ		CYLINDER BLOCK: ENGINE, MULTIFUEL 10889717 (19207)		1										1	25

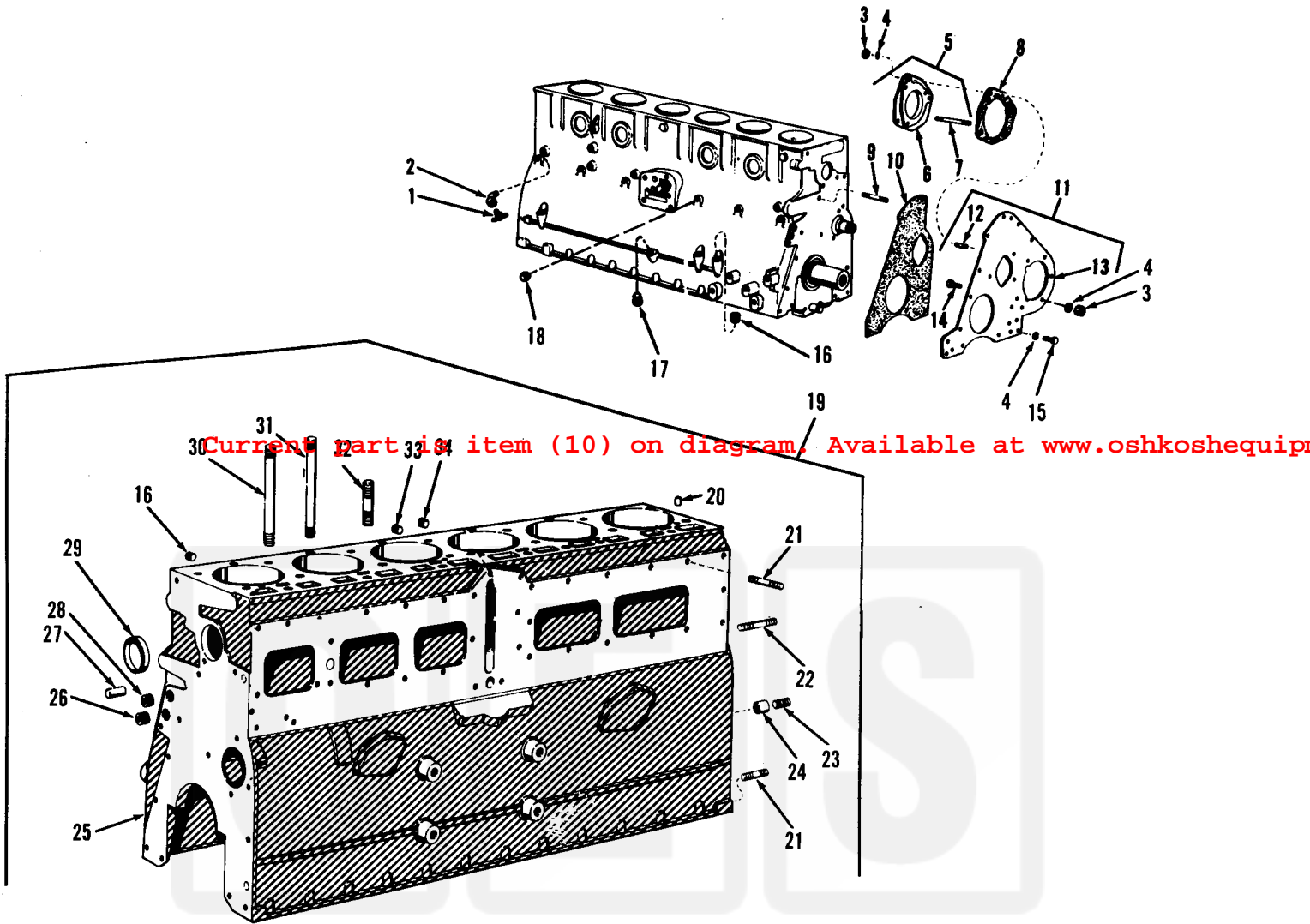

Current part is item (10) on diagram. Available at www.oshkoshequipment.com



TA010707

Figure 1. Crankcase, Front Plate and Associated Parts.